



# EA-KC2 Series Membrane Keypad Access Controller

Electronic access

- **Simplified, secure access management**
- **Attractive, customizable membrane style keypad**
- **Programmable to accommodate multiple access arrangements**
- **Direct integration with electronic locks**
- **Controls up to two compartments independently**
- **Sleep mode for minimal power draw**
- **Up to 120 user codes**
- **LED indicators for keypad status & programming**

The Membrane Keypad Access Controller simplifies access management with keyless entry in a self-contained unit. Designed to accommodate industrial equipment needs, the Membrane Keypad is easily customized and can be simply adhered to a door or frame. The remote controller can be mounted anywhere inside a cabinet and provides two outputs for independent control of two separate compartments. Flexible and easy to use, it can be customized to accommodate any look, shape or feel.

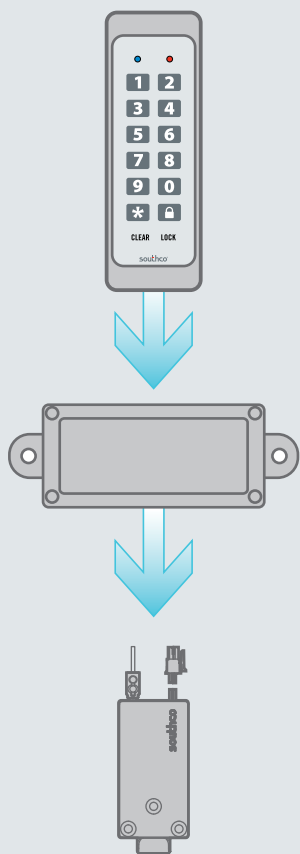

## The Membrane Keypad benefits a variety of industrial applications



Self Service



Medical Storage



Server Racks

Other options available. For complete details on variety, part numbers, installation and specification, go to



[www.southco.com/EA-KC2](http://www.southco.com/EA-KC2)

Dimensions in millimeters (inch) unless otherwise stated

**southco**  
CONNECT · CREATE · INNOVATE

# EA-KC2 Series Keypad Access Controller

## Electronic access



### Horizontal Key Pad Part Number EA-KC2-101

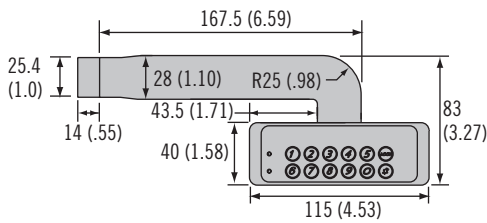

### Vertical Key Pad Part Number EA-KC2-102, EA-KC2-103 & EA-KC2-104

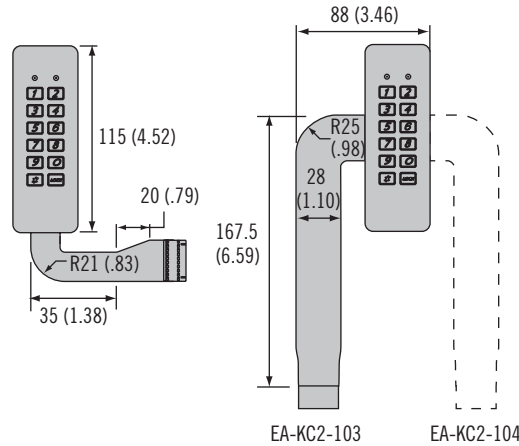

### Controller Assembly Part Number EA-KC2-201

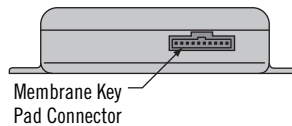
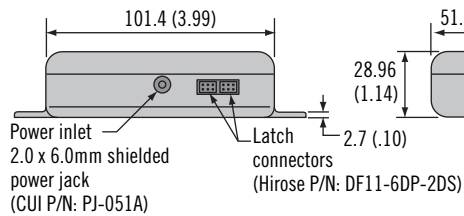
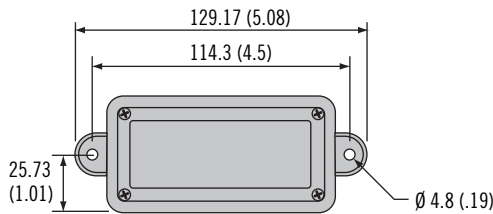

EA-KC2-102 Vertical Membrane Key Pad

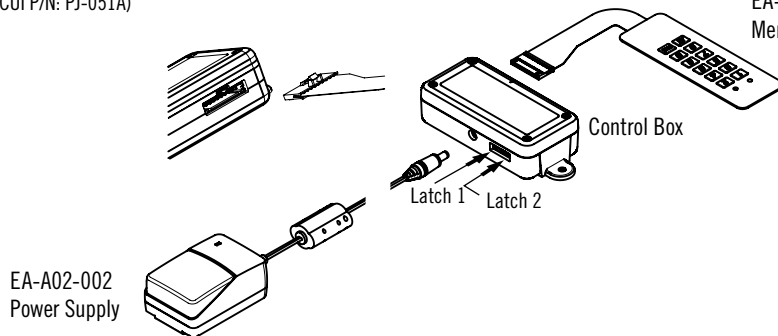

| LATCH WIRE HARNESS OPTIONS |   |  |
|----------------------------|---|--|
| Part Number                | Description   |  |
| EA-W01-200*                | 2 Meter Wire Harness Stripped and Tinned  |  |
| EA-W20-201-01*             | 2 Meter Wire Harness to Connect Membrane Controller to Miniature Electronic Keeper (EM-05-XX-XXX) and/or Electronic Rotary Latch (R4-EM-XX-XXX) |  |
| EA-W01-200-01*             | 2 Meter Wire Harness to Connect Membrane Controller to Electronic Swing Handle (H3-EM-XX-XXX)   |  |

\*Contact Southco For Custom Lengths

### Plug Adapters

| Part Number               | Description                  | Function |
|---------------------------|------------------------------|----------|
| EA-A02-002**              | Power Supply with NA 2-Pin   |          |
| EA-A02-002 & EA-A02-002-2 | Power Supply with Euro 2-Pin |          |
| EA-A02-002 & EA-A02-002-3 | Power Supply with UK 3 Pin   |          |
| EA-A02-002 & EA-A02-002-4 | Power supply with SAA 2-Pin  |          |

\*\*EA-A02-002-1 NA 2-PIN included with EA-A02-002 Power Supply.

Dimensions in millimeters (inch) unless otherwise stated

### Material & Finish

Membrane Key Pads with Tactile Keys - Textured Polyester Film with PSA Tape for Mounting on Backside  
Controller Housing - ABS  
Controller Circuit Board - FR4

### Electrical Specifications

Supply Voltage: 12-24 VDC  
Stand By Current: 30µA  
Operating Current: 10mA (Typical)  
MAX Total Output: 4 Amps (2 Amps per Output)

### How to Order

- Order one controller EA-KC2-201
- Order standard Southco membrane EA-KC2-101, EA-KC2-102, EA-KC2-103 & EA-KC2-104. Contact Southco for custom membrane keypad design.
- Order Southco Power Supply EA-A02-002 and select the appropriate plug adapter if needed.



- Use latch wire harness options table to select cable to accommodate Southco EML

